

## SPECIFICATION

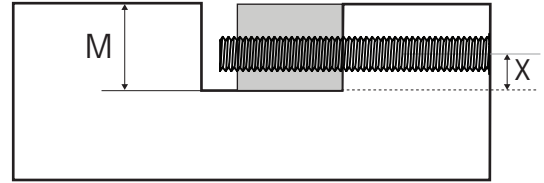
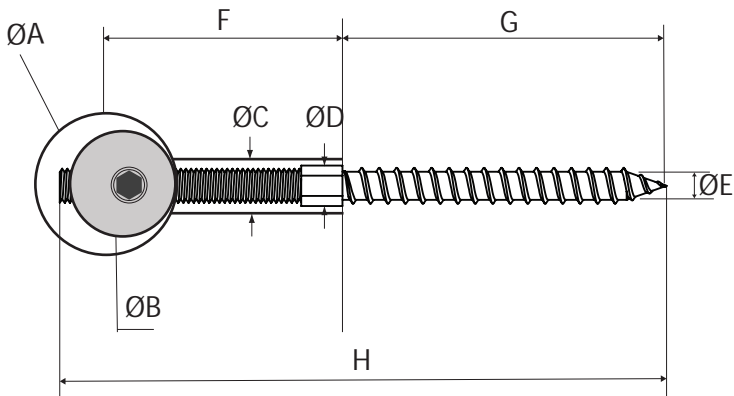

M= Minimum Bore Depth 13mm (1/2 inches)  
 X = Shaft Centre 5mm (3/16 inches)

## Measurements

	Millimetres	Inches
A	19	3/4
B	15	19/32
C	8	5/16
D	6	
E	5	3/16
F	38	1 1/2
G	47	1 7/8
H	88	3 7/16



4mm hex bit

