

SPECIFICATION

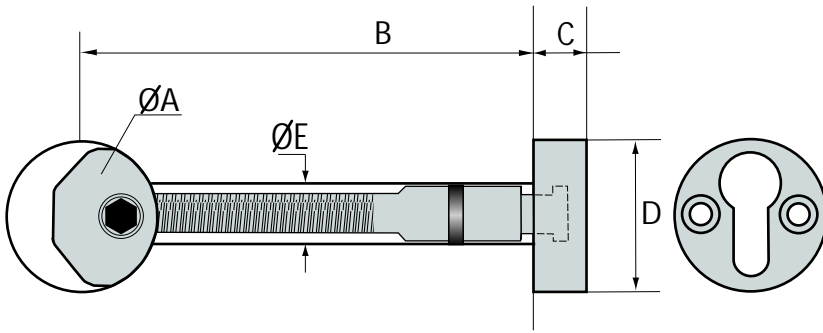

SHAFT CENTRE CALCULATION

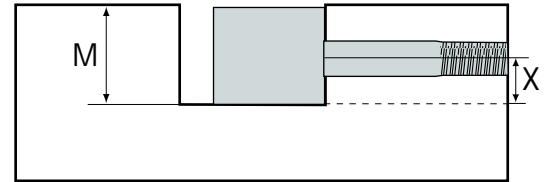

M = Minimum Bore Depth 20mm (51/64 inches)
 X = Shaft Centre 10mm (25/64 inches)

Measurements

	Millimitres	Inches
A	25	1
B	89	3 1/2
C	7	9/32
D	25	1
E	9.5-10	3/8

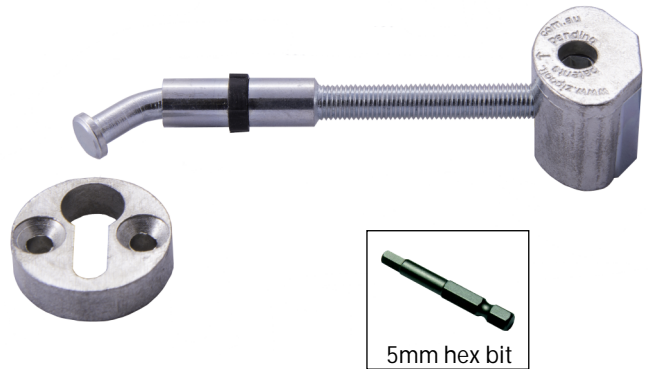

5mm hex bit

