

## SPECIFICATION

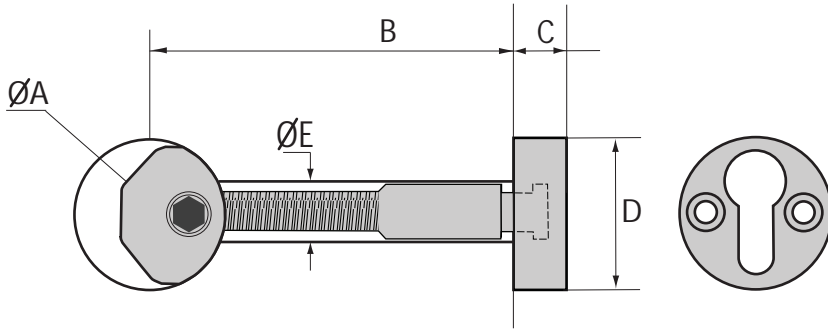

## SHAFT CENTRE CALCULATION

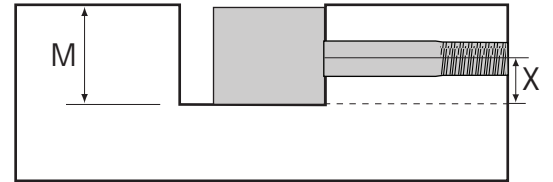

M = Minimum Bore Depth 20mm (51/64 inches)  
 X = Shaft Centre 10mm (25/64 inches)

## Measurements

	Millimetres	Inches
A	25	1
B	38	1 1/2
C	7	9/32
D	25	1
E	9.5-10	3/8

