

SPECIFICATION

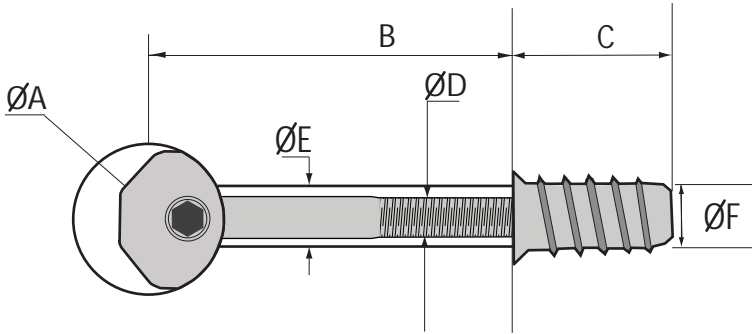

SHAFT CENTRE CALCULATION

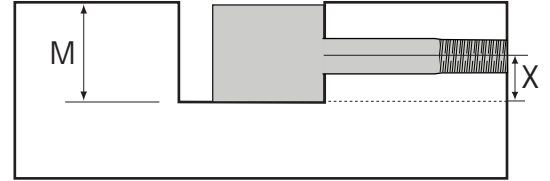

M= Minimum Bore Depth 20mm (51/64 inches)
 X = Shaft Centre 10mm (25/64 inches)

Measurements

	Millimetres	Inches
A	25	1
B	50-60	1 ³¹ / ₃₂ - 2 ²³ / ₆₄
C	31	1 ⁷ / ₃₂
D	8	5/ ₁₆
E	9	23/ ₆₄
F	12	15/ ₃₂



A variation of bore size of 12.5mm -13mm for Insert Screw (F) may be required for hardwoods or when drilling into end grain. Use waxing or lubrication if required to level Insert Screw flush in the material. If required countersink hole to ensure Insert Screw is flush or below surface level of material.

