

## SPECIFICATION

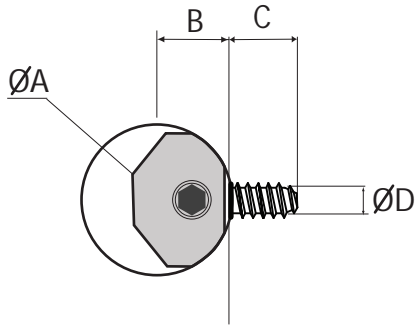

### SHAFT CENTRE CALCULATION

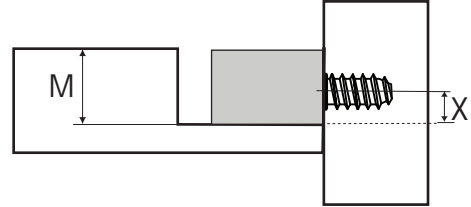

M= Minimum Bore Depth 12.5mm (31/64 inches)  
 X = Shaft Centre 5.5mm (13/64 inches)

## Measurements

	Millimetres	Inches
A	25	
B	12	
C	12	
D	5	

