

## SPECIFICATION

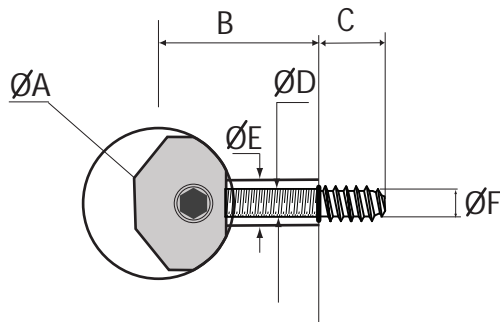

### SHAFT CENTRE CALCULATION

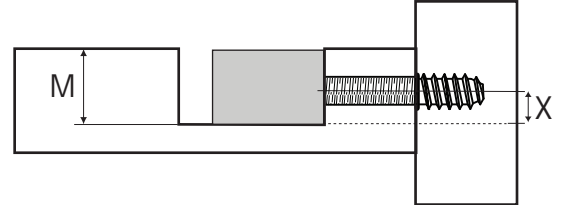

M= Minimum Bore Depth 12.5mm (31/64 inches)  
 X = Shaft Centre 5.5mm (13/64 inches)

## Measurements

|   | Millimetres | Inches |
|---|-------------|--------|
| A | 25          |        |
| B | 25          |        |
| C | 12          |        |
| D | 6           |        |
| E | 7           |        |
| F | 5           |        |

