

SPECIFICATION

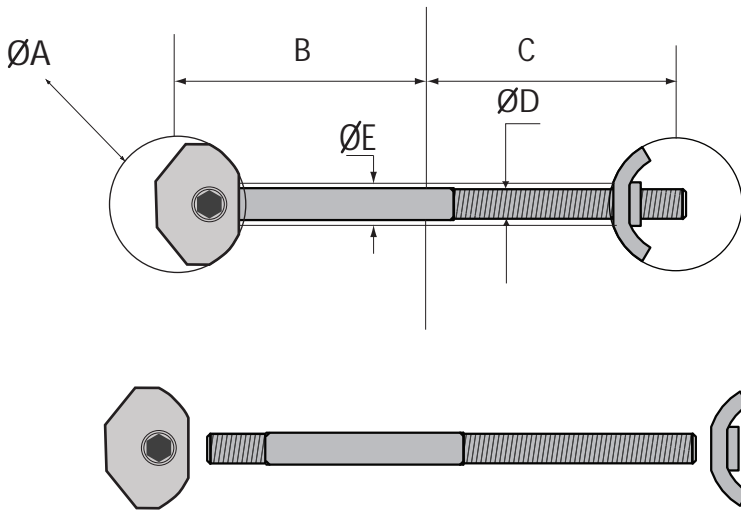

SHAFT CENTRE CALCULATION

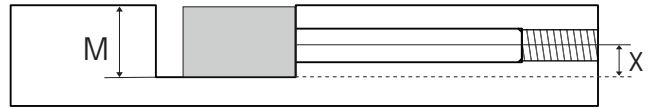

M= Minimum Bore Depth 12.5mm (31/64 inches)
 X = Shaft Centre 5.5mm (13/64 inches)

Measurements

	Millimetres	Inches
A	25	1
B	38 - 44	1 1/2 - 1 47/64
C	38 - 44	1 1/2 - 1 47/64
D	6	15/64
E	7	9/32

