

# #13.600 - Railbolt

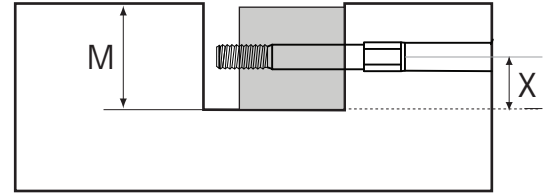

## SPECIFICATION

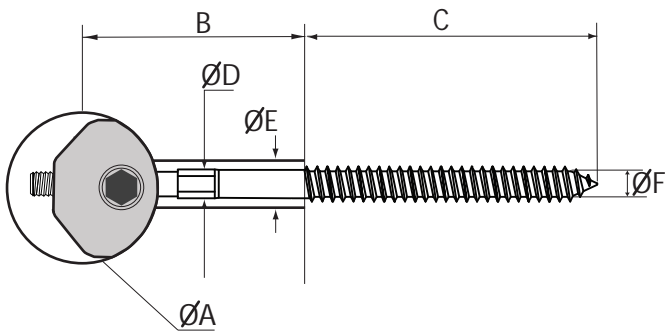

M= Minimum Bore Depth 20mm (51/64 inches)  
X = Shaft Centre 10mm (25/64 inches)

## Measurements

|   | Millimitres | Inches                         |
|---|-------------|--------------------------------|
| A | 25          | 1                              |
| B | 38          | 1 <sup>1</sup> / <sub>2</sub>  |
| C | 52          | 2 <sup>3</sup> / <sub>32</sub> |
| D | 7           |                                |
| E | 9 - 10      | <sup>3</sup> / <sub>8</sub>    |
| F | 6 - 7       | <sup>1</sup> / <sub>4</sub>    |

